

New

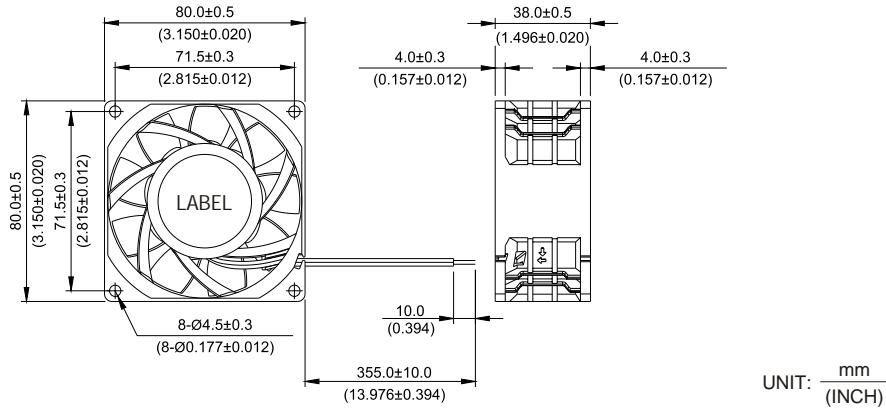

PFB 80 x 80 x 38 MM SERIES

DIMENSIONS DRAWING



- * Bearing Type
Ball Bearings
- * Material
Impeller & Frame: Plastic (UL94V-0)
- * Lead Wires :
UL 1007 AWG #24 OR Equivalent
Red Wire Positive (+)
Black Wire Negative (-)
- * Weight : 205g (7.23 oz)

P & Q CURVE (AT RATED VOLTAGE)

MOUNTING PANEL CUTOUT

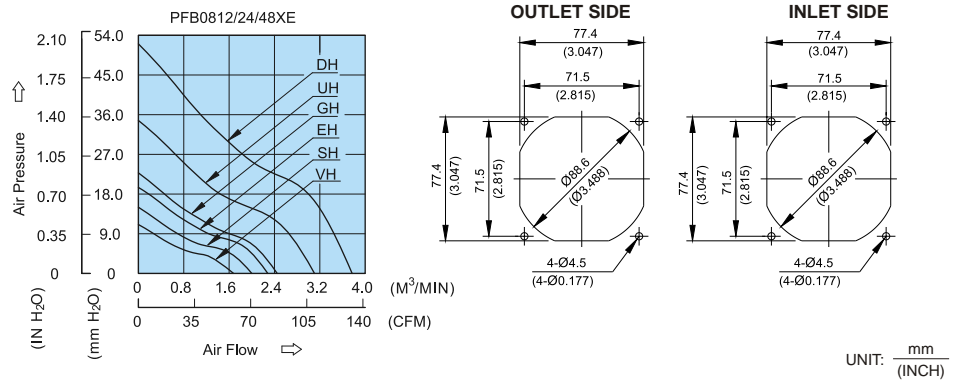

MODEL		Rated Voltage	Operating Voltage Range	Rated Current	Rated Input Power	Speed	Maximum Air Flow		Maximum Air Pressure		Noise
PART NO.	FUNCTION	VDC	VDC	Amp	Watt	R.P.M.	m ³ /min	CFM	mmH ₂ O	IN H ₂ O	dB-A
PFB0812VHE	- R00 / - F00	12	7.0 to 13.2	0.39	4.68	4200	1.649	58.23	10.70	0.421	45.1
PFB0812SHE	- R00 / - F00	12	7.0 to 13.2	0.51	6.12	4900	1.967	69.49	14.53	0.571	49.3
PFB0812EHE	- R00 / - F00	12	7.0 to 13.2	0.72	8.64	5600	2.243	79.23	19.50	0.767	53.0
PFB0824EHE	- R00 / - F00	24	14.0 to 26.4	0.36	8.64						
PFB0848EHE	- R00 / - F00	48	28.0 to 56.0	0.23	11.04	6100	2.448	86.44	22.80	0.898	55.5
PFB0812GHE	- R00 / - F00	12	7.0 to 13.2	0.85	10.20						
PFB0824GHE	- R00 / - F00	24	14.0 to 26.4	0.45	10.80						
PFB0848GHE	- R00 / - F00	48	28.0 to 56.0	0.27	12.96	7500	3.038	107.30	34.75	1.368	61.0
PFB0812UHE	- R00 / - F00	12	7.0 to 13.2	1.55	18.60						
PFB0824UHE	- R00 / - F00	24	14.0 to 26.4	0.77	18.48	9000	3.754	132.56	51.57	2.030	65.0
PFB0848UHE	- R00 / - F00	48	28.0 to 56.0	0.42	20.16						
PFB0812DHE	- R00 / - F00	12	7.0 to 13.2	2.75	33.00						
PFB0824DHE	- R00 / - F00	24	14.0 to 26.4	1.35	32.40						

* Function type is optional.
 * The max. air flow and the speed are measured in free air ; max. air pressure is measured at zero air flow.
 * Noise is measured in anechoic chamber in free air, one meter from intake side.
 * All readings are typical values at rated voltage.
 * Specifications are subject to change without notice.